

Copyright. All information furnished within this document, electronic file or design correspondence is the property of Den Hartog industries, Inc. and shall not be used, disclosed to others or copied without the expressed written consent of Den Hartog Industries, Inc.

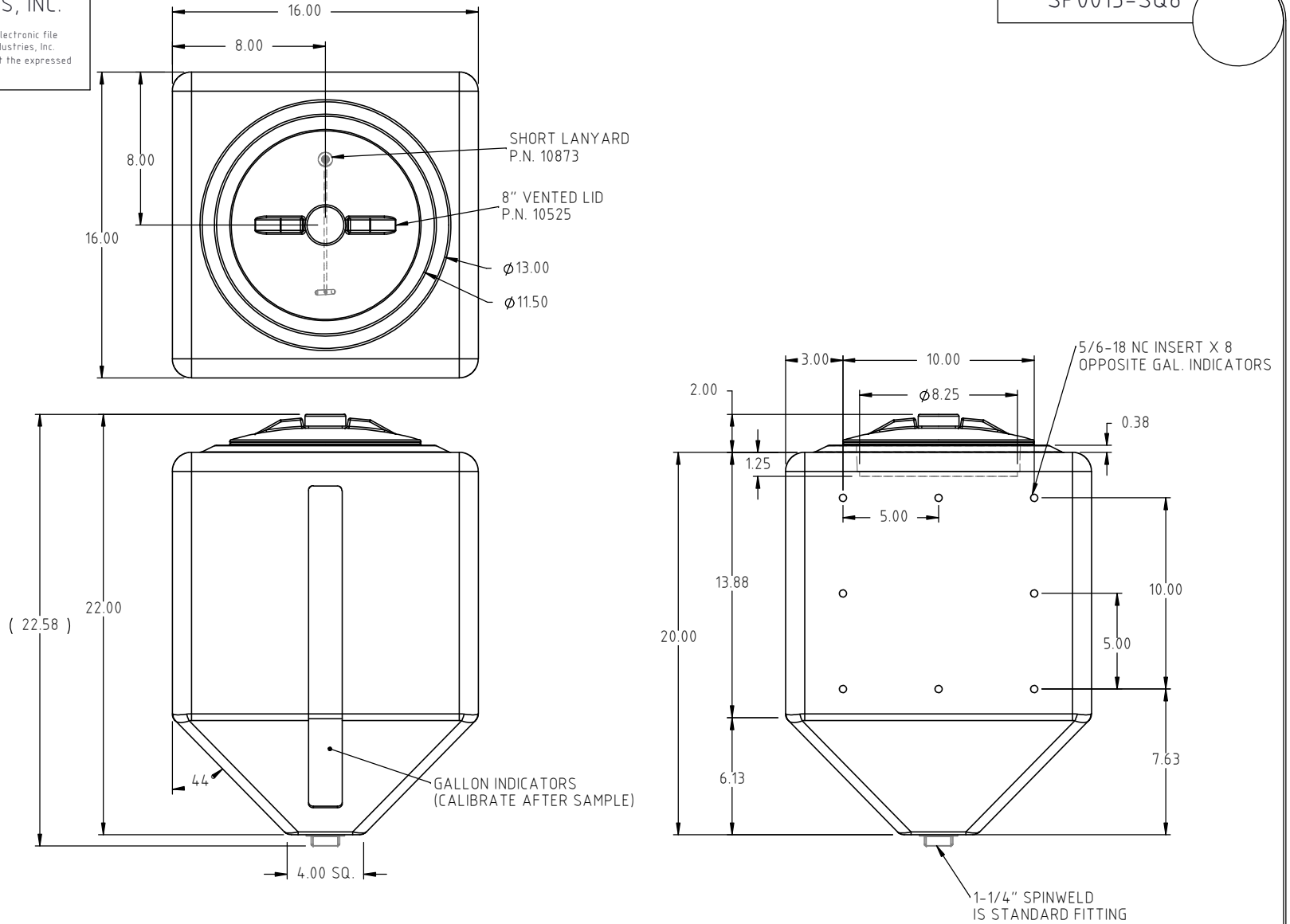

REV	DESCRIPTION	BY / DATE	CCN	DRAWN / DATE ADH 6/20/14	MATERIAL 10420 NATURAL
				APPROD. / DATE REH 6/23/14	
ALL DIMENSIONS ARE IN DECIMAL INCHES TOLERANCES UNLESS OTHERWISE SPECIFIED		THIRD ANGLE PROJECTION ANSI 14.5M		SHOT WEIGHT: 13.5 LBS.	NOTES: 1.) .250 NOMINAL WALL
POLYETHYLENE		METAL DECIMAL ± .125" FRACTION ± 1/4" ANGLE ± 1°		SHIPPING WEIGHT: 15.5 LBS	
±1% @ 68°F				FINISH:	

Den Hartog

INDUSTRIES, INC.

Ace Roto-Mold Injection Molding Blow Molding Sowjoy

4010 HOSPERS DRIVE S. BOX 425, HOSPERS, IOWA 51238-0425

DESCRIPTION 15 GALLON RINSE TANK	
SCALE N.S.	PART NO. SP0015-SQ8